

Heavy duty electric concertina ladder in alloy for use in premium applications.

CUSTOMER PROFILE:

- **Domestic customers** who want the convenience of an automated operating system. Maximum in strength and load capacity.
- **Commercial customers** who want an electrically operated heavy duty ladder for safe and easy specific internal access for storage or to access air-conditioning, telecommunications, electrical, plant or other equipment.

CUSTOMER BENEFITS:

- German engineered, tested and certified to EN 14975 (European Ladder Standard).
- 24 volt low noise drive equipped with automatic limit stop and safety stop, plus emergency power supply.
- 2 wall switches included.
- Meets the provisions of the Building Code of Australia (BCA).
- Range of height applications for maximum convenience.
- Top step is mounted in box for easy exit from ladder.
- Wide, deep non-skid treads and gentle 65° ladder angle mean safe, easy climbing.
- Articulated hatch offers maximum climbing safety.
- Wide 700mm opening in choice of various lengths gives maximum everyday access and fits space constraints.
- Constructed of all alloy and plated parts for strength, durability and reliability.
- Adjustable double heavy duty tension and control springs and heavy duty hinges for easy, safe opening and closing operation.
- Strong, stable 200kg per step load capacity for long life with heavy or commercial use.
- Handrail is standard for climbing stability.

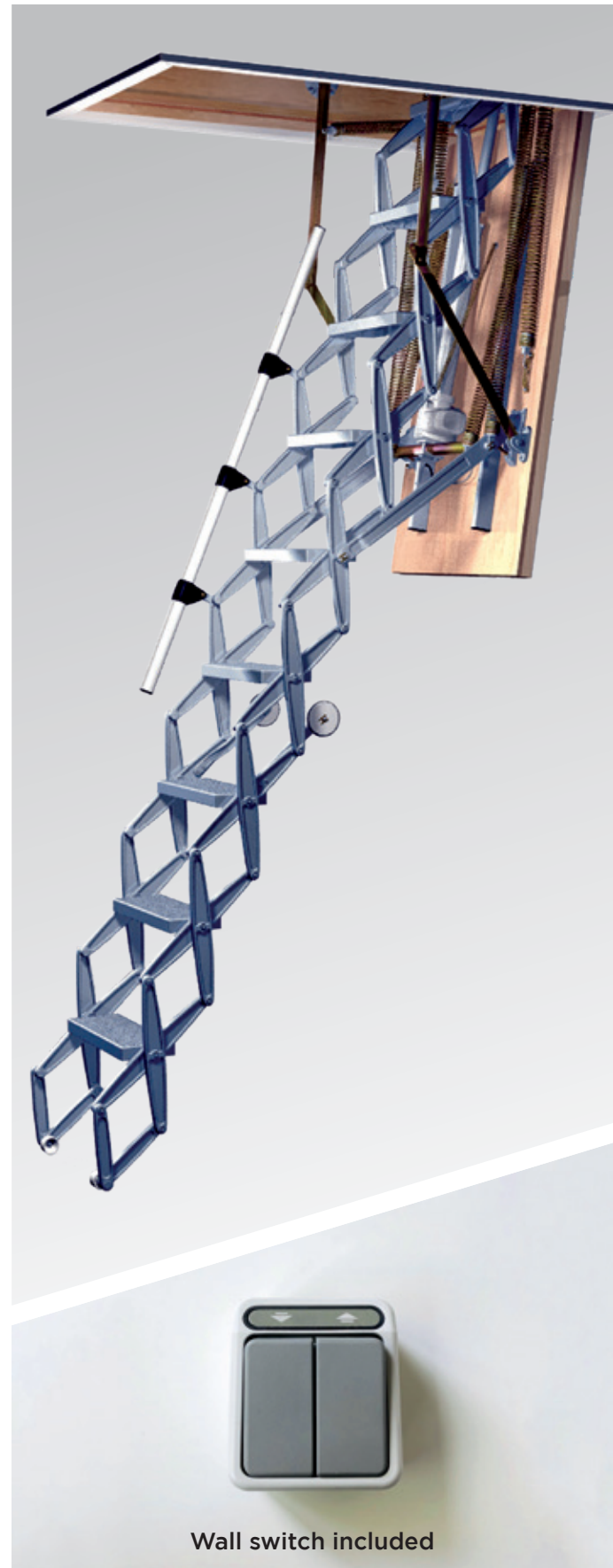

TECHNICAL SPECIFICATIONS:

Columbus Electric metal concertina ladder

Model	Cut-out Size* (A/B)	Floor-ceiling(E) (No of treads)	Standout (C)	Foldout (D)
Electric 11	700 x 1300mm	up to 3.09m (11)	1460mm	1700mm
Electric 13	700 x 1450mm	up to 3.69m (13)	1520mm	1900mm

* Frame size is typically 10mm less than the cut-out dimensions stated above

Dimensions

	Tread	Stile	Packed	Casing
Depth	140mm	concertina	1300-1450mm	1300-1450mm
Thickness	19mm	concertina		240x19mm
Width	300mm	concertina	700mm	700mm
Weight	65-70 kg			
Load capacity	200 kg / tread			

Materials

Tread	Stile	Hatch	Casing
Alloy	Alloy	Laminated	Laminated

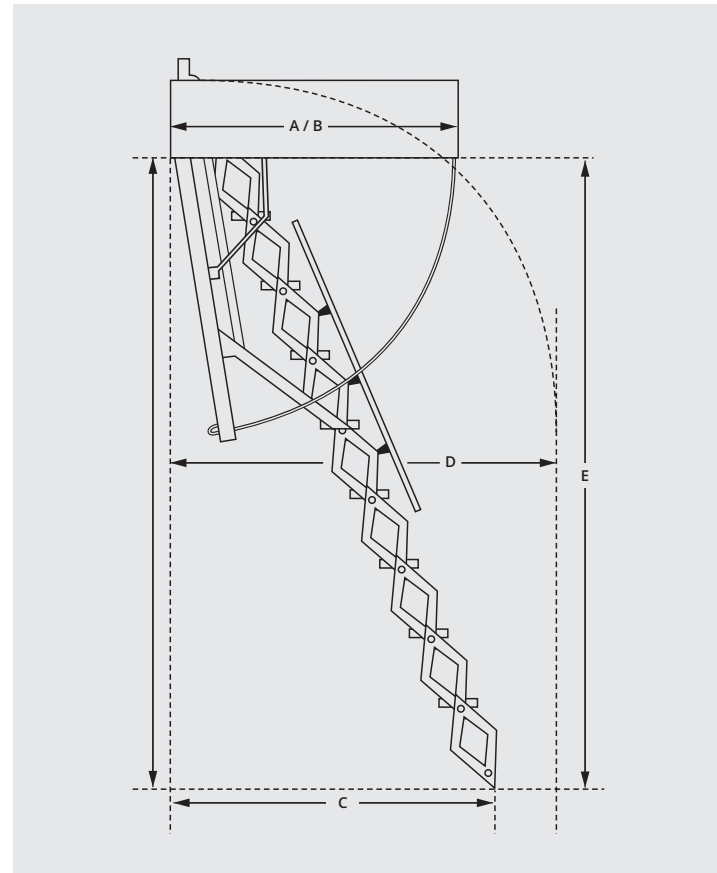

OPTIONAL EXTRAS

Accessory	Application
Balustrade	Added security of a rail around your ceiling opening
Ceiling hand rail	Metal loop handrail in ceiling for extra safety



FEATURES:

- Low-noise electric motor securely extends and retracts the stairway.
- Heavy duty construction in lightweight alloy.
- Insulated trap door 62mm thick.
- Alloy or plated metal parts.
- Plated adjustable balance springs.
- Wide, non-slip step treads.
- Gentle 65° access slope.
- Comes supplied with 1 x telescopic handrail as standard. Safety handrail can be fitted to either side.
- Completely assembled from factory.

Ask about our dust proof room package deals.

SYDNEY Heritage Business Park 1/5-9 Ricketty Street, Mascot NSW 2020 | P: 02 9018 0000 | E: syd@atticgroup.com.au

MELBOURNE 1269 North Road, Oakleigh VIC 3166 | P: 03 9575 3700 | E: melb@atticgroup.com.au